

RoHS

REV.	EC#	DESCRIPTION	DATE	DRAWING	CHECKED	APPROVED
A0		NEW RELEASE	2019.10.24	Michael	Mark	Cornelia

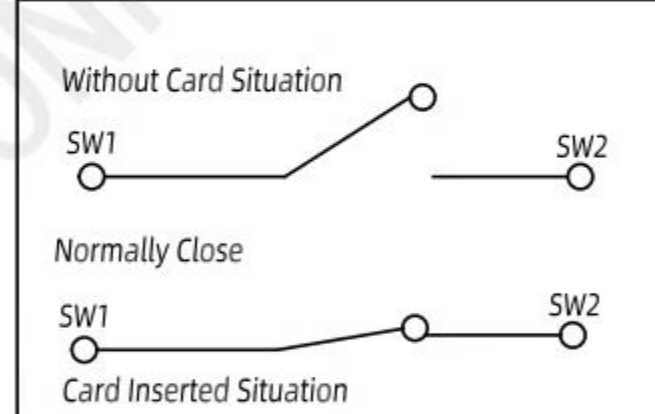
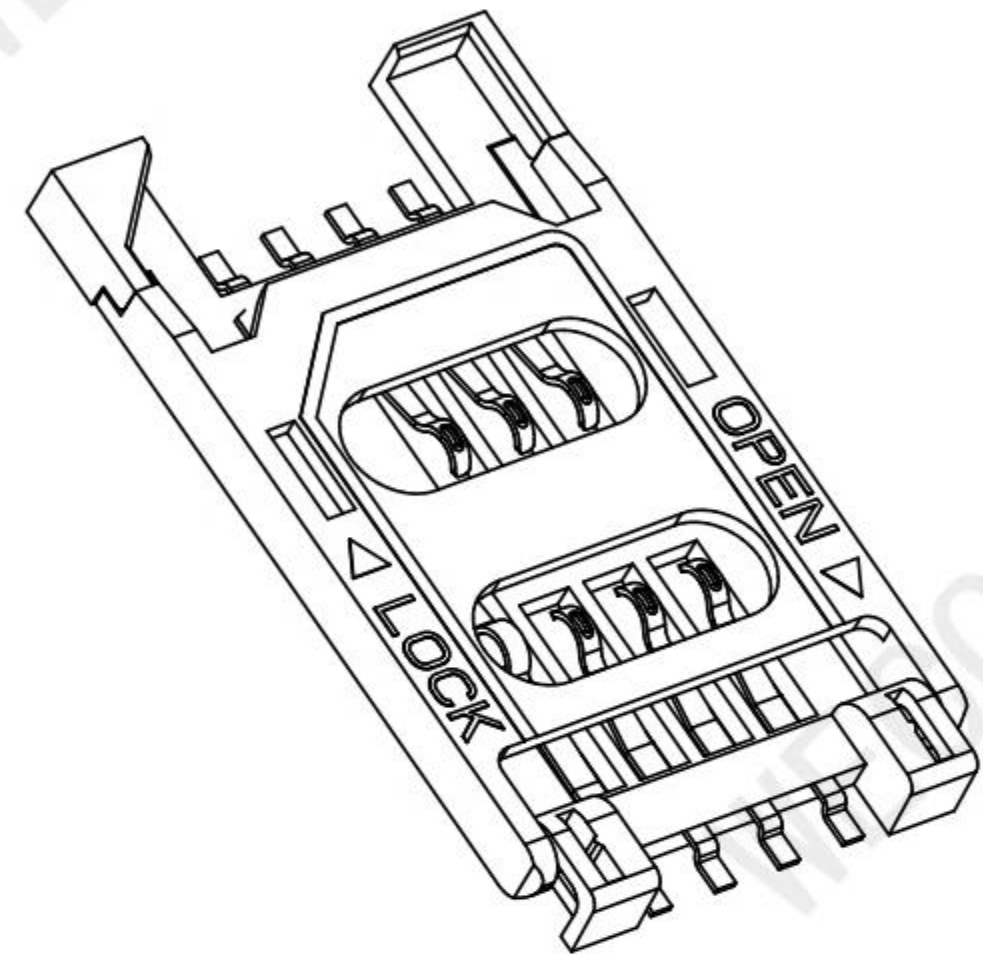
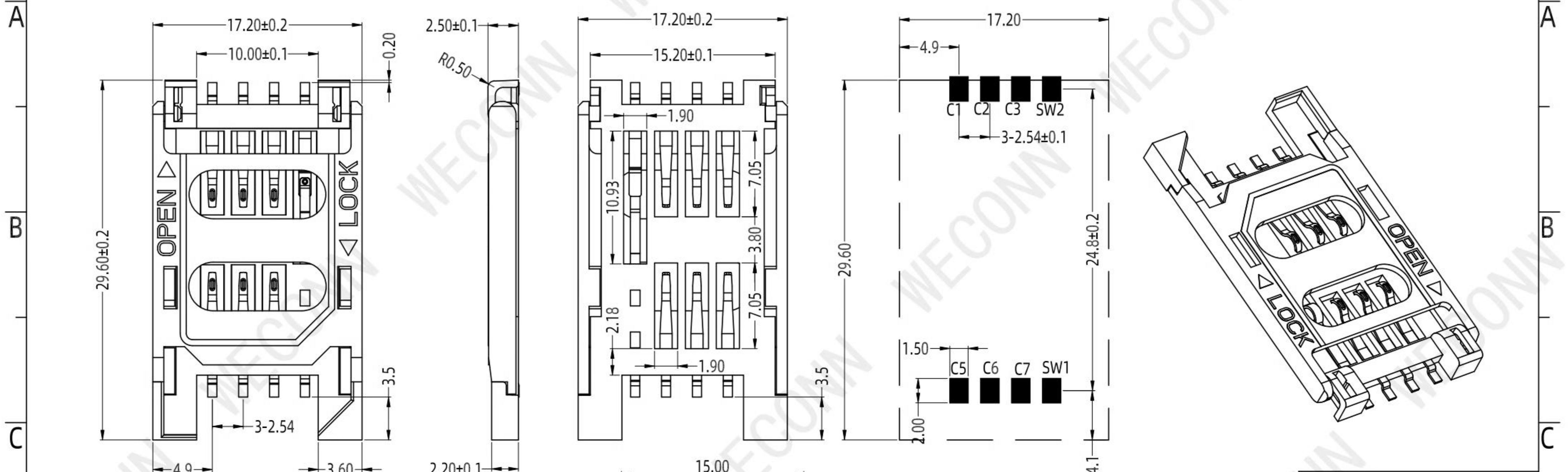

SPECIFICATION:

- 1.Life:10000Cycles Min.
- 2.Contact Force:0.2~1.0N.(Card thickness 0.76mm)
- 3.Contact resistance:50mΩ, typical,100mΩ Max.
- 4.Insulation resistance:Min 1000MΩ/500V DC .
- 5.open/lock force: 6N ± 3N
- 6.Flat post:IRBefore and after CP8 0.10mm Max;plastic0.20mm Max.

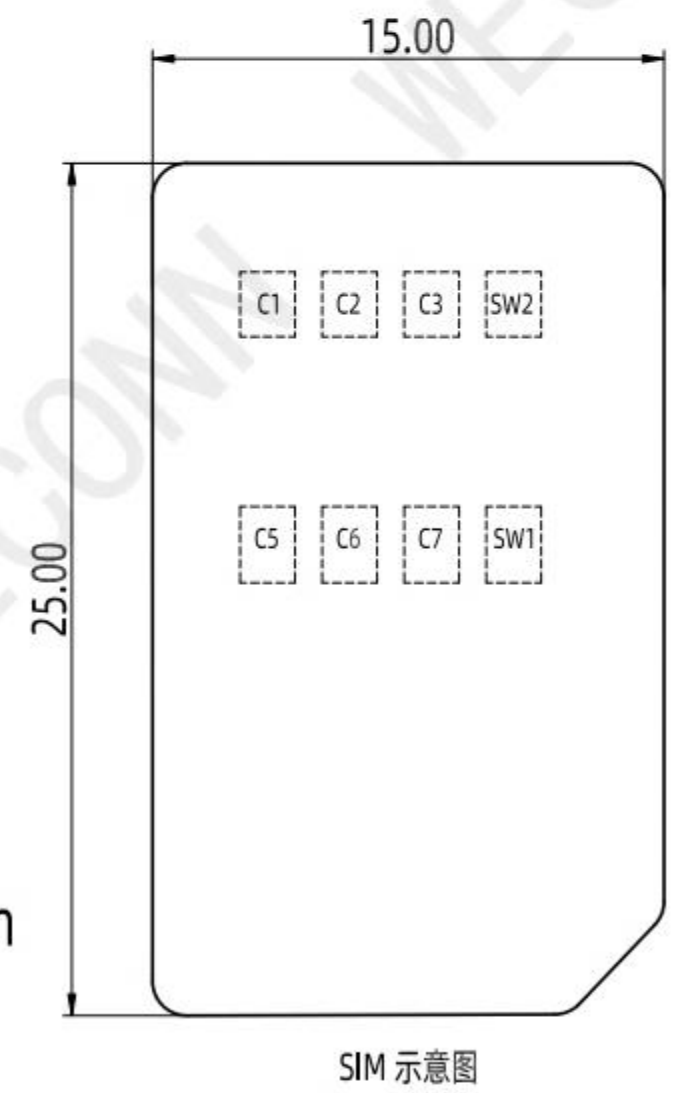

PIN#	Name
C1	VCC
C2	RST
C3	CLK
C5	GND
C6	VPP
C7	I/O
SW1	C/D
SW2	GND

Table A	
Material	plastic LCP E130i BK HF
Terminal plating	C5210R-H T=0.20mm HF
The overall nickel base is 50u*Min, the contact area is brushed 3u*Min, The welding area is immersed in pure matte tin 100u*Min.	

MILLIMETERS	INCH	UNITS	WECONN® 深圳市微连电子有限公司 ShenZhen Welink Electronics Co.,Ltd		
X° ± 2°	X° ± 2°	MM	PART NUMBER: WL-SIM521-62-NA1		TITLE: SIM卡座 翻盖式 6P+2 黑色小孔 带开关
.X ± 0.30	.XX ± 0.012	MAT'L SEE NOTES	DWG NO.: WL-SIM521-62-NA1		APPD: Cornelia
.XX ± 0.20	.XXX ± 0.008	FINISH SEE NOTES	SCALE SHEET REV. 1:1 1/2 A1		CHKD: Mark
.XXX ± 0.10	.XXXX ± 0.004	QTY SEE NOTES	DR: Michael		

PLEASE CONTACT WELINK SALES REPRESENTATIVE TO VERIFY PRODUCT DETAILS & AVAILABILITY

THESE DRAWINGS AND SPECIFICATION ARE Welink ShenZhen Welink Electronics Co.,Ltd COPIED OR USED IN ANY MANNER WITHOUT Welink ShenZhen Welink Electronics Co.,Ltd

RoHS

REV.	EC#	DESCRIPTION	DATE	DRAWING	CHECKED	APPROVED
A0		NEW RELEASE	2019.10.24	Michael	Mark	Cornelia

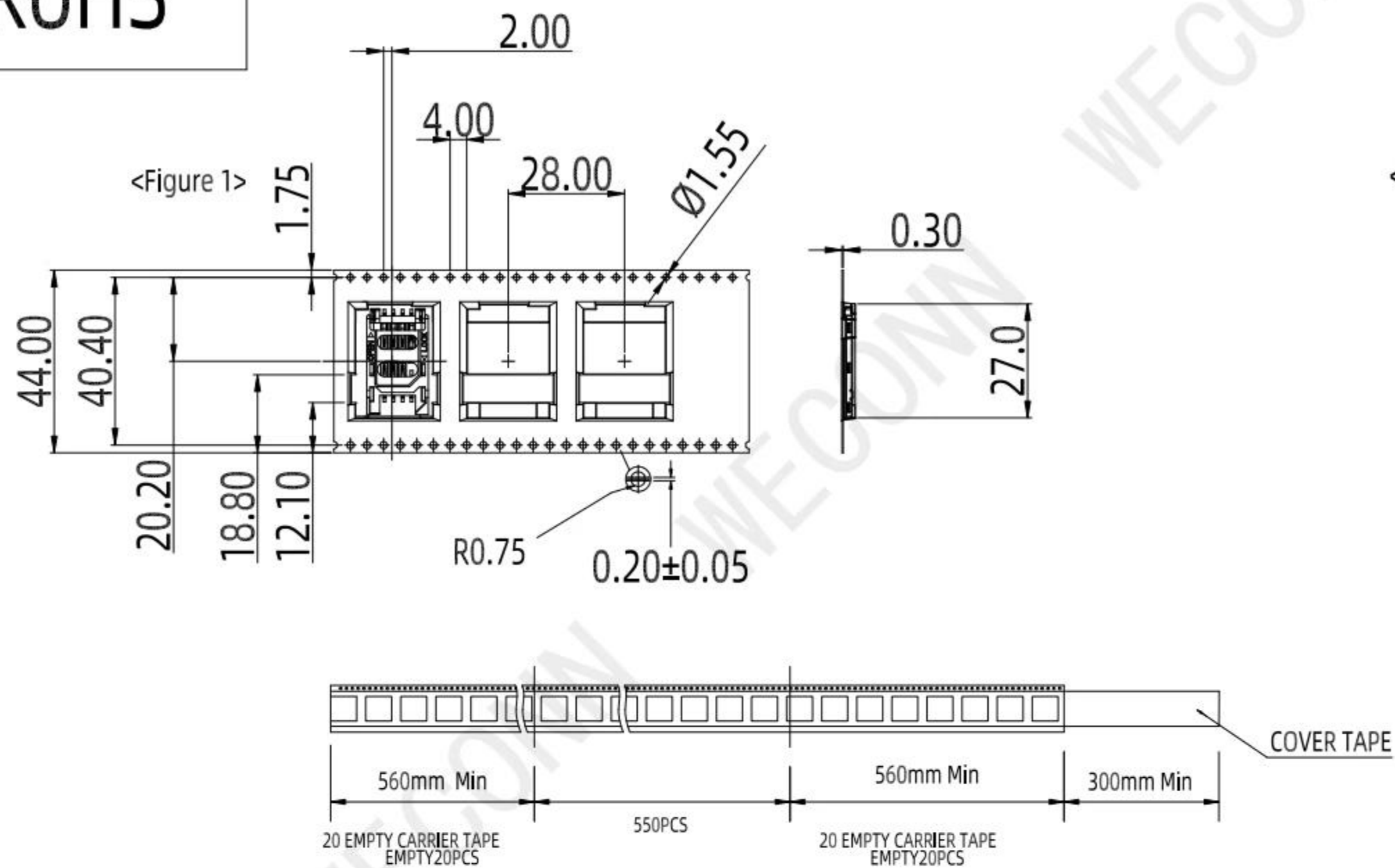

<Figure 2>

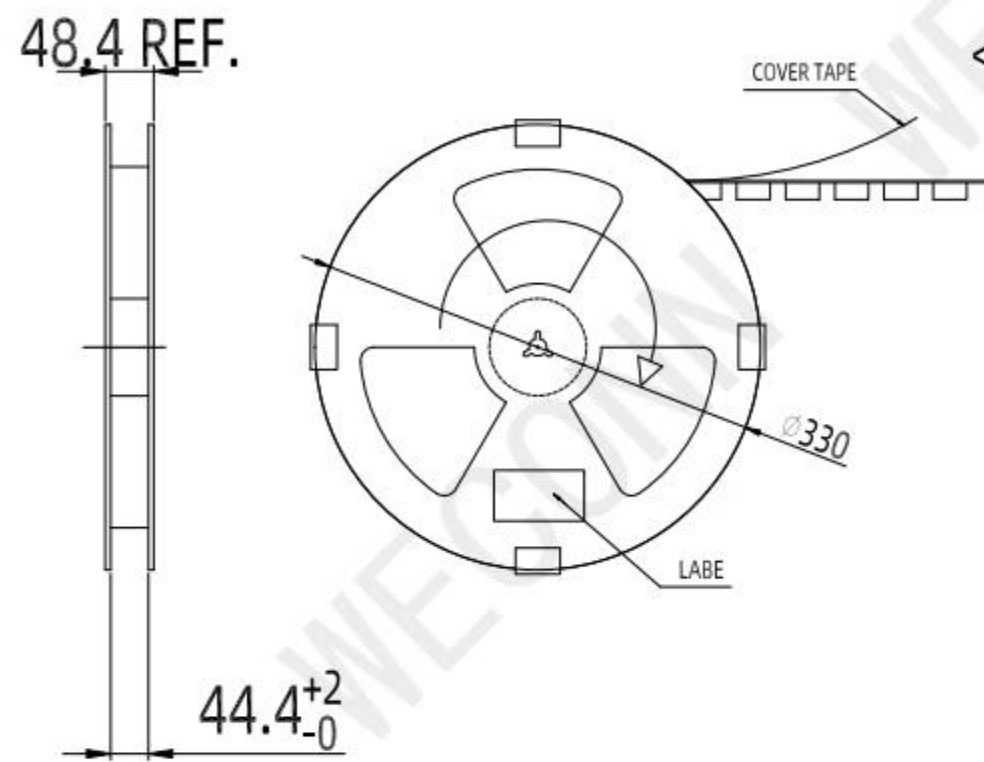

<TABLE 1> PACKAGING QUANTITY

QTY/REEL	REEL/CARTON	QTY/CARTON
600	6	3600

COVER TAPE PEELING FORCE: 20gf~120gf

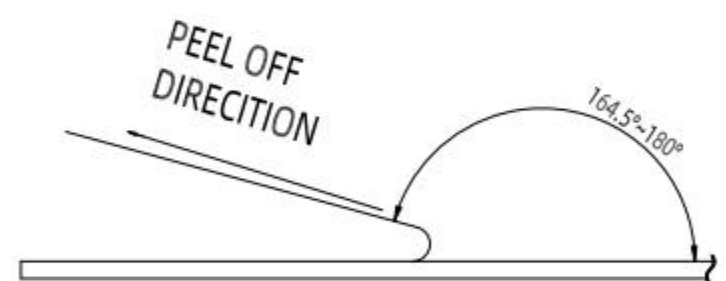

<Figure 3>

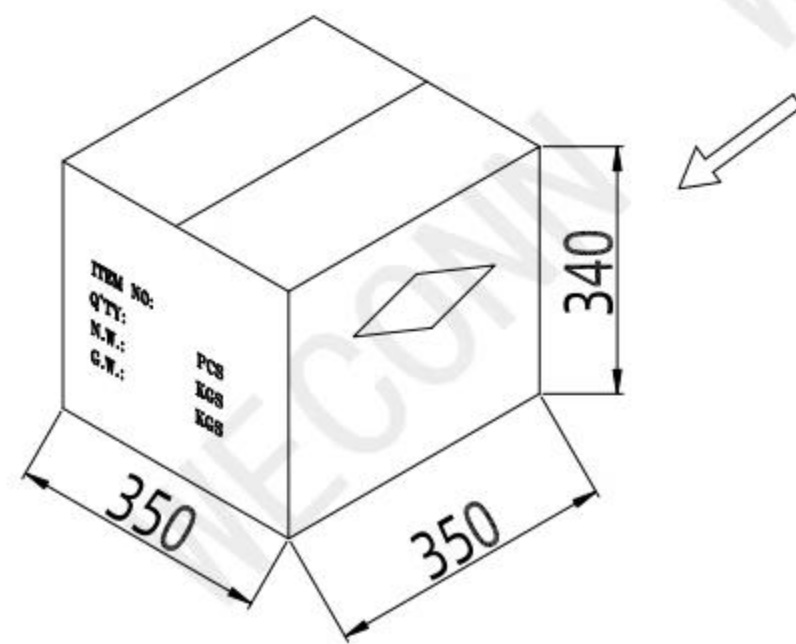
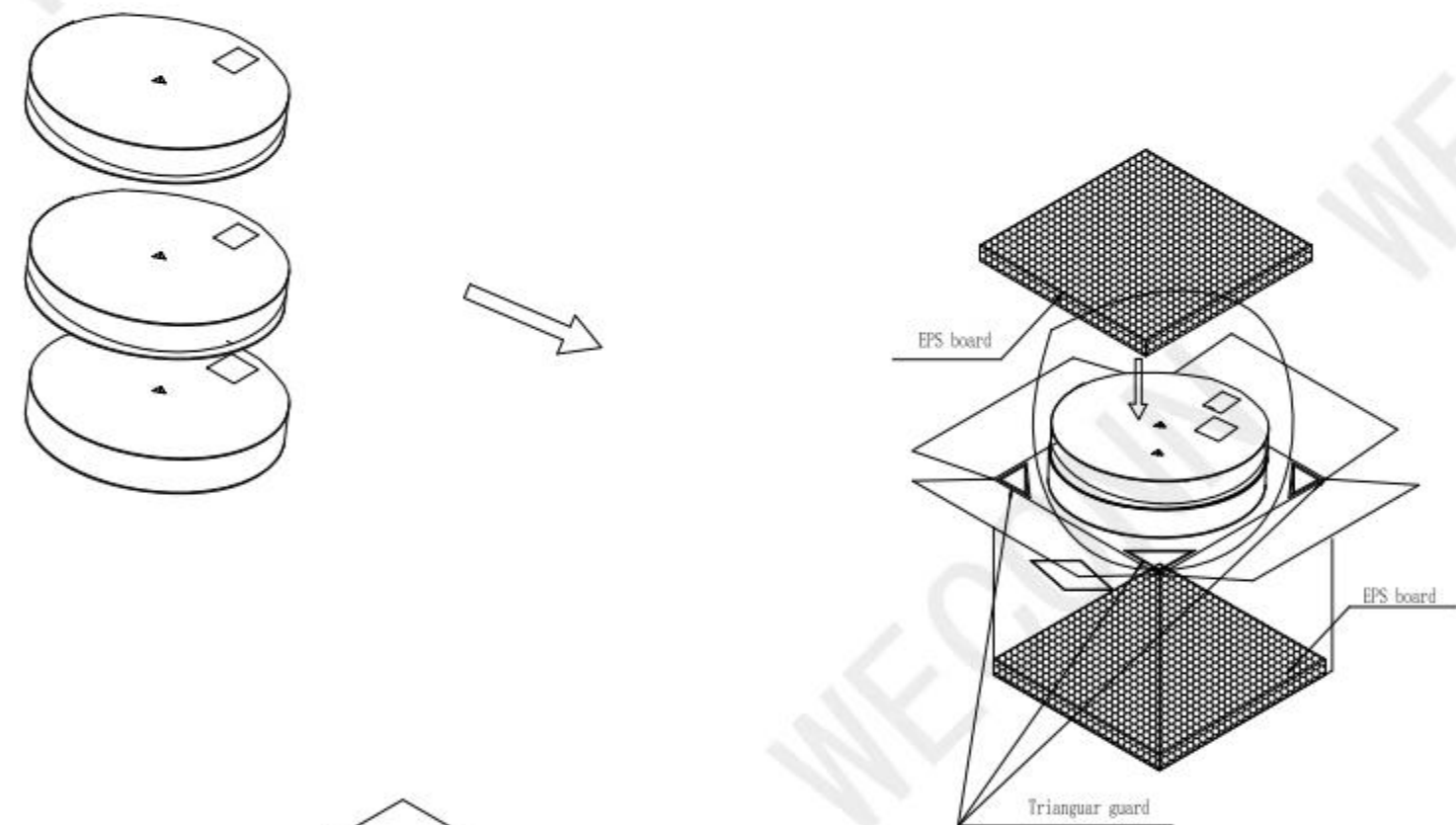

NOTE:

- Place 1 PCS product per hole according to <Figure 1>.
 - After the packaging machine is wrapped, stick tape on each equal point of the REEL to prevent the REEL from scattered. Label each REEL, as shown in <Figure 2>
 - The packaging quantity is shown as <TABLE 1>
 - Package, as shown in <Figure 3>
- Put the EPS board at the bottom of the box, and then put the REEL into the box. Put four triangular guards into the four corners, and put the EPS board on the top.
- Seal the box, write the material number, quantity, etc. on the sealed carton according to customer requirements

MILLIMETERS	INCH	UNITS	WECONN® 深圳市微连电子有限公司 ShenZhen Welink Electronics Co.,Ltd			
X.° ± 2°	X.° ± 2°	MM	PART NUMBER:		TITLE:	
.X ± 0.30	.XX ± 0.012	MAT'L	WL-SIM521-62-NA1		SIM卡座 翻盖式 6P+2 黑色小孔 带开关	
.XX ± 0.20	.XXX ± 0.008	SEE NOTES	FINISH		APPD: Cornelia	
.XXX ± 0.10	.XXXX ± 0.004	SEE NOTES	QTY		CHKD: Mark	
THESE DRAWINGS AND PECIFICATION ARE Welink ShenZhen Welink Electronics Co.,Ltd COPIED OR USED IN ANY MANNER WITHOUT Welink ShenZhen Welink Electronics Co.,Ltd			DWG NO.:		DR: Michael	
			SCALE	SHEET	REV.	
			1:1	2/2	A1	