

RoHS

REV.	EC#	DESCRIPTION	DATE	DRAWING	CHECKED	APPROVED
A0		NEW RELEASE	2022.04.28	Michael	Mark	Cornelia

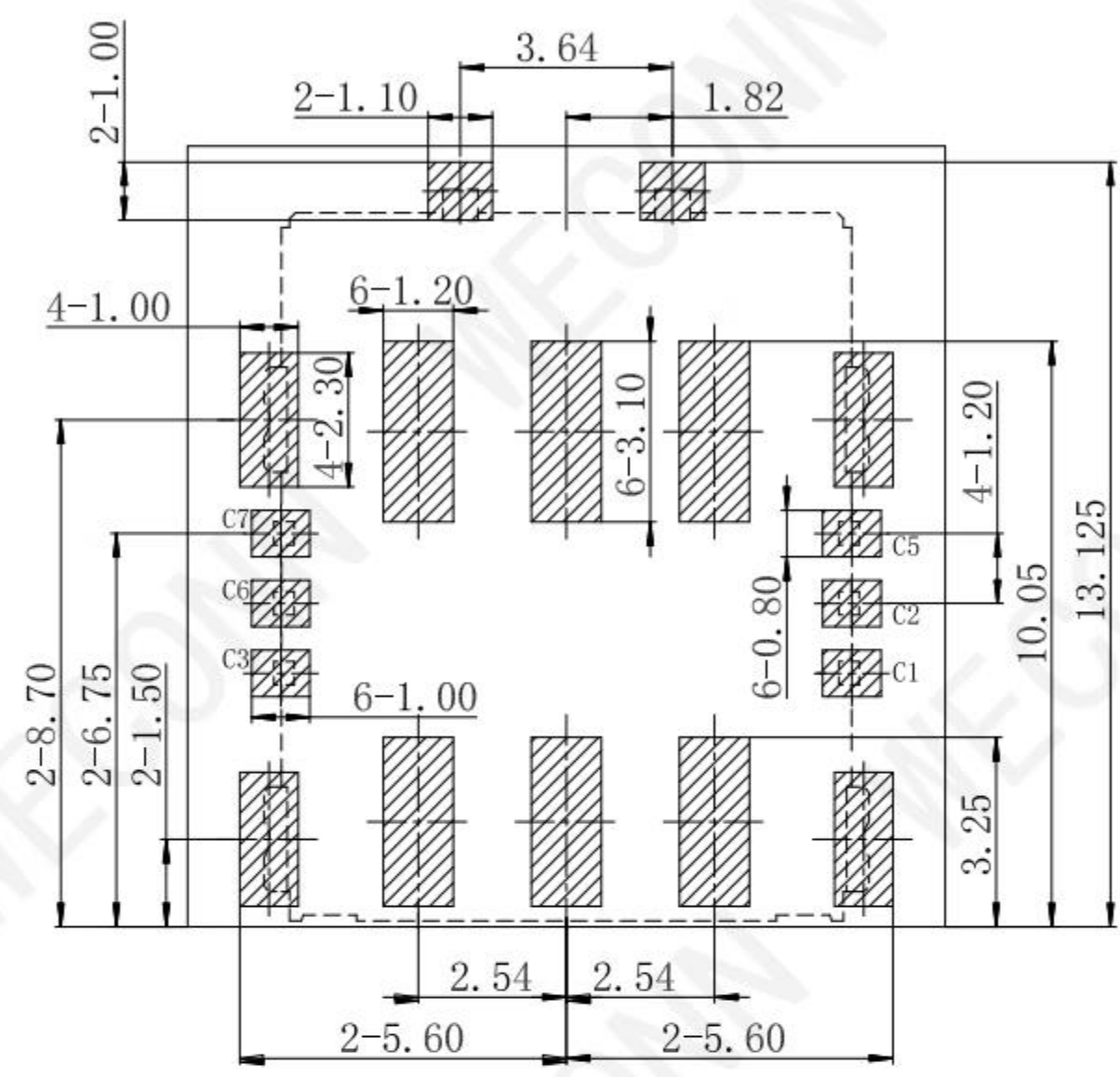
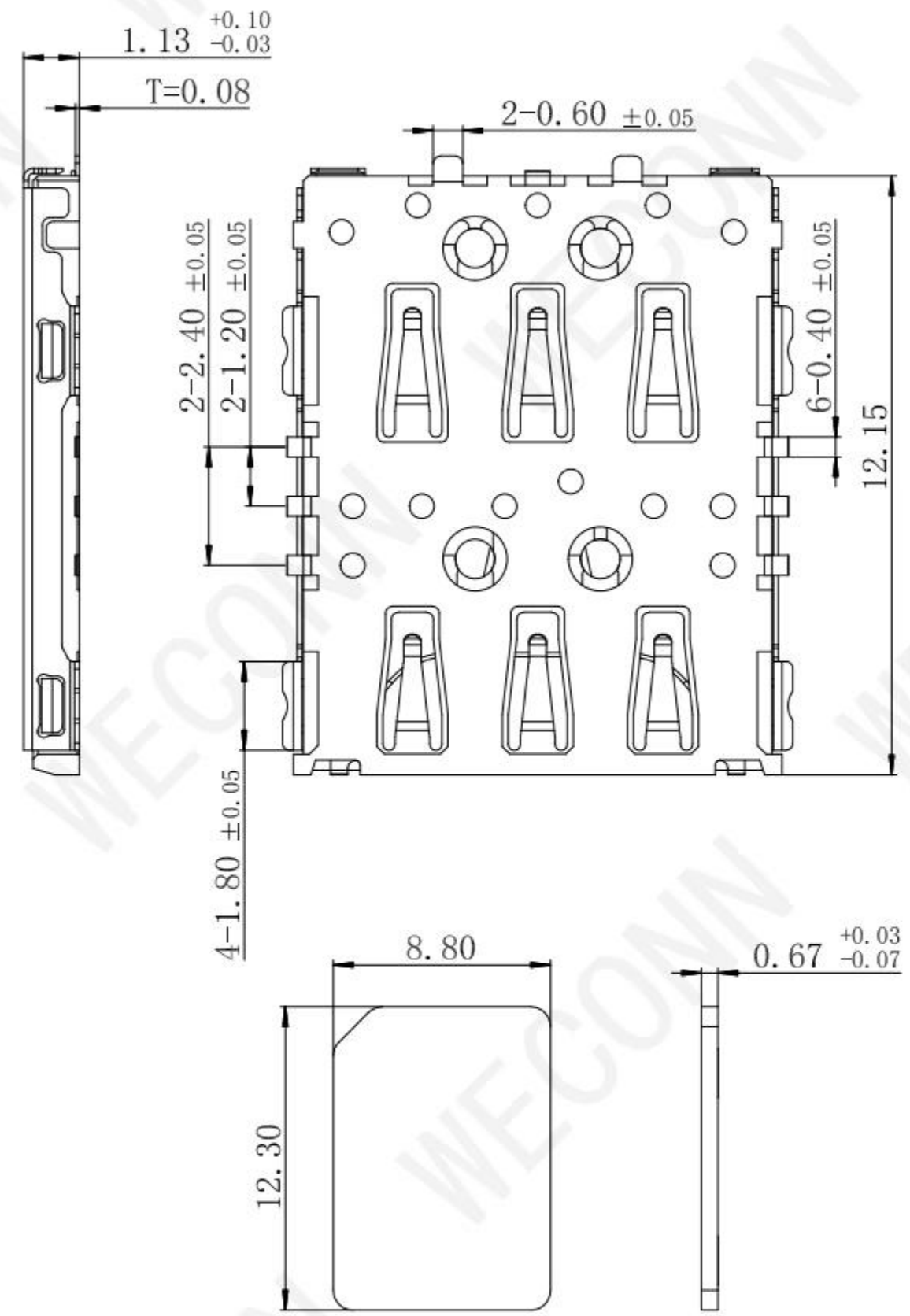
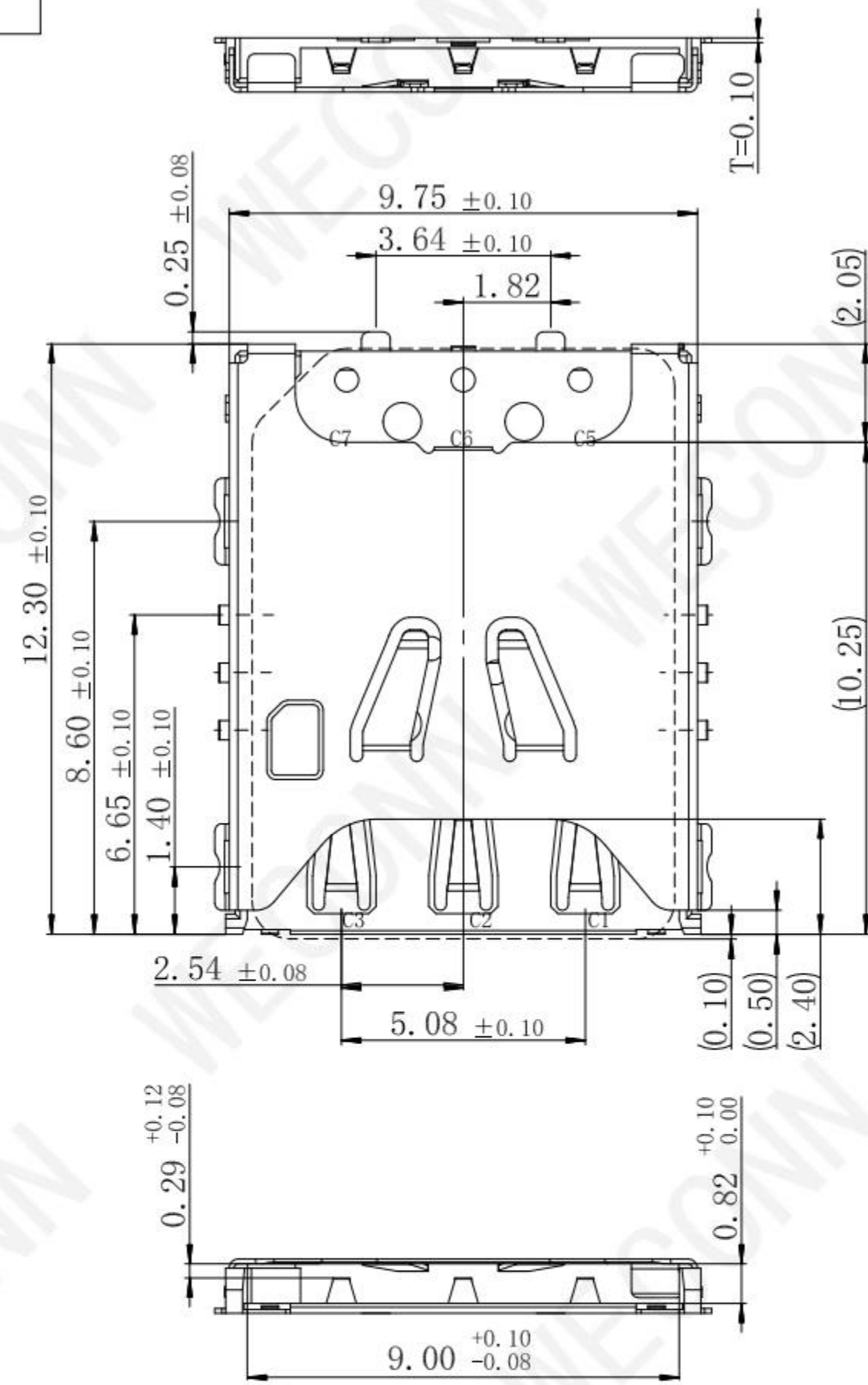

RECOMMENDED PCB LAYOUT
 TOLERANCE: ± 0.05
 SMT SOLDER AREA
 COPPER RESTRICTED AREA
 1. TOUCH AREA OF CONTACT
 TIPS NO ELECTRICAL FUNCTION
 2. NO FIRST PCB_LAYOUT
 CIRCUITS IN THE AREA

- NOTES:
- MATERIAL:**
 HOUSING: High Temperature Thermoplastic
 Terminal: Copper Alloy
 Shell: Stainless Steel
 - PLATING:**
 Terminal: 50u" Ni UNDERPLATED OVERALL
 1u" Au PLATED ON CONTACT AREA AND SOLDER AREA
 Shell: 50u" Ni UNDERPLATED OVERALL
 - TECHNICAL SPECIALITY:**
 RATED VOLTAGE: 30V AC MAX.
 CURRENT RATING: 0.5A MAX.
INSULATION RESISTANCE: 1000MΩ MIN
CONTACT RESISTANCE: 100mΩ MAX
 WITHSTANDING VOLTAGE: 500V AC FOR 1 MINUTES
OPERATING TEMPERATURE: -20°C~+85°C Humidity 80% R.H MAX

PLEASE CONTACT WELINK SALES REPRESENTATIVE
 TO VERIFY PRODUCT DETAILS & AVAILABILITY

PIIN/NO	ASSIGNMENT	MILLIMETERS	INCH	UNITS	WECONN® 深圳市微连电子有限公司 ShenZhen Welink Electronics Co.,Ltd			
C1	VCC	X. ± 0.2	X.° ± 5°	MM	PART NUMBER:		TITLE:	
C2	RST	.X ± 0.15	.X° ± 2°	MAT'L	WL-SIM113-027C		1.13H NO-PUSH NANO-SIM CARD	
C3	CLK	.XX ± 0.1	.XX° ± 1°	SEE NOTES	DWG NO.:		APPD:	Cornelia
C5	GND	.XXX ± 0.01	.XXX° ± 0.5°	SEE NOTES	WL-SIM113-027C		CHKD:	Mark
C6	VPP	THESE DRAWINGS AND PECIFICATION ARE Welink ShenZhen Welink Electronics Co.,Ltd COPIED OR USED IN ANY MANNER WITHOUT Welink ShenZhen Welink Electronics Co.,Ltd		QTY	SCALE	SHEET	REV.	DR:
C7	I/O			SEE NOTES	1:1	1/2	A1	Michael

RoHS

REV.	EC#	DESCRIPTION	DATE	DRAWING	CHECKED	APPROVED
A0		NEW RELEASE	2022.04.28	Michael	Mark	Cornelia

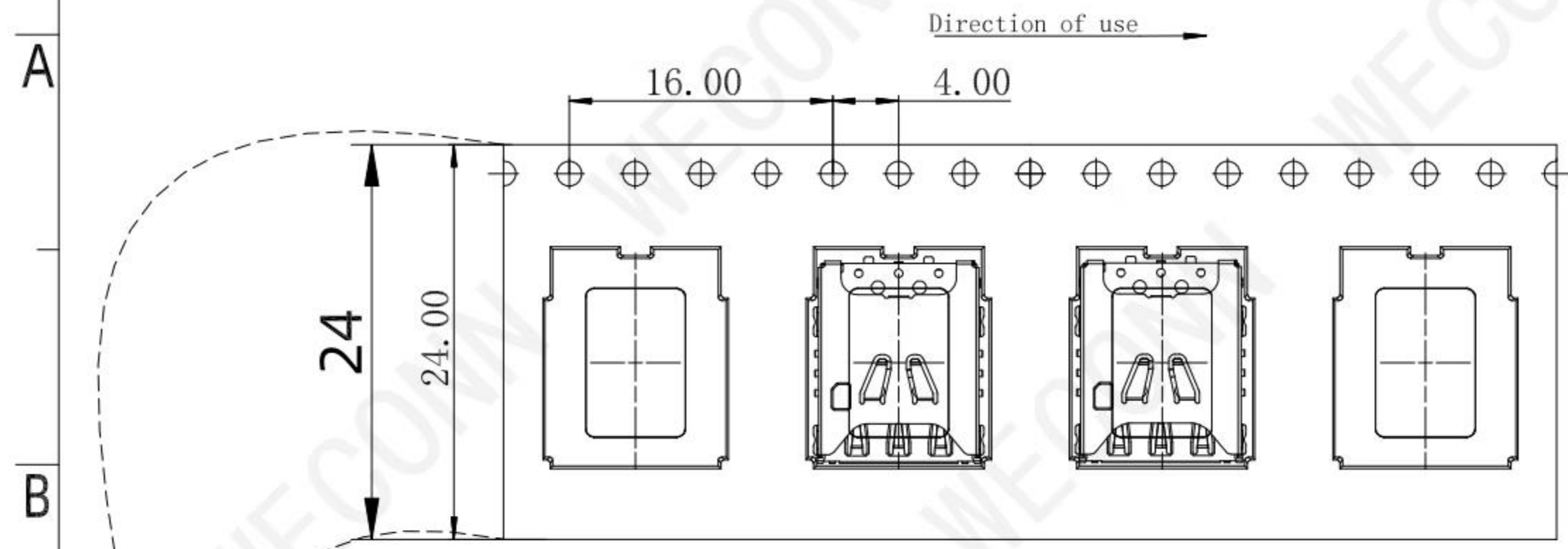

NOTES:

- 1、 Packing quantity per plate: 2000PCS/Plate
- 2、 Loading and packing method

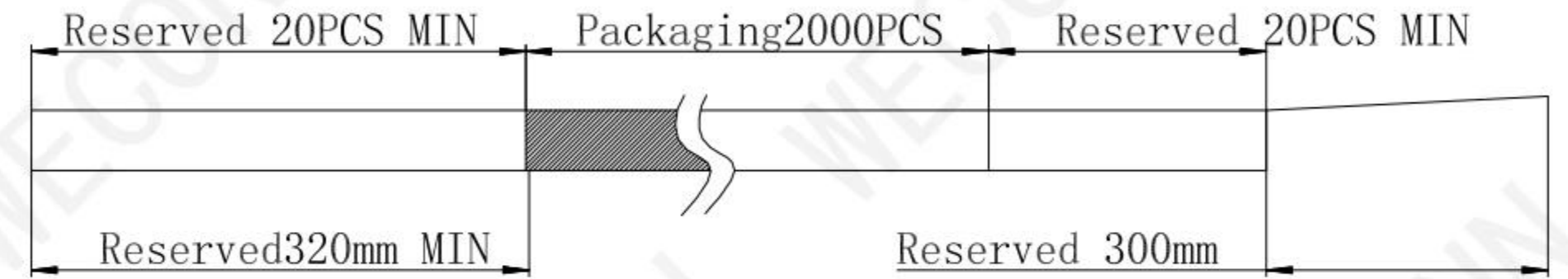

3、 Total packaging: 20000PCS/Box

COVER TAPE PEELING FORCE: 20gf~120gf

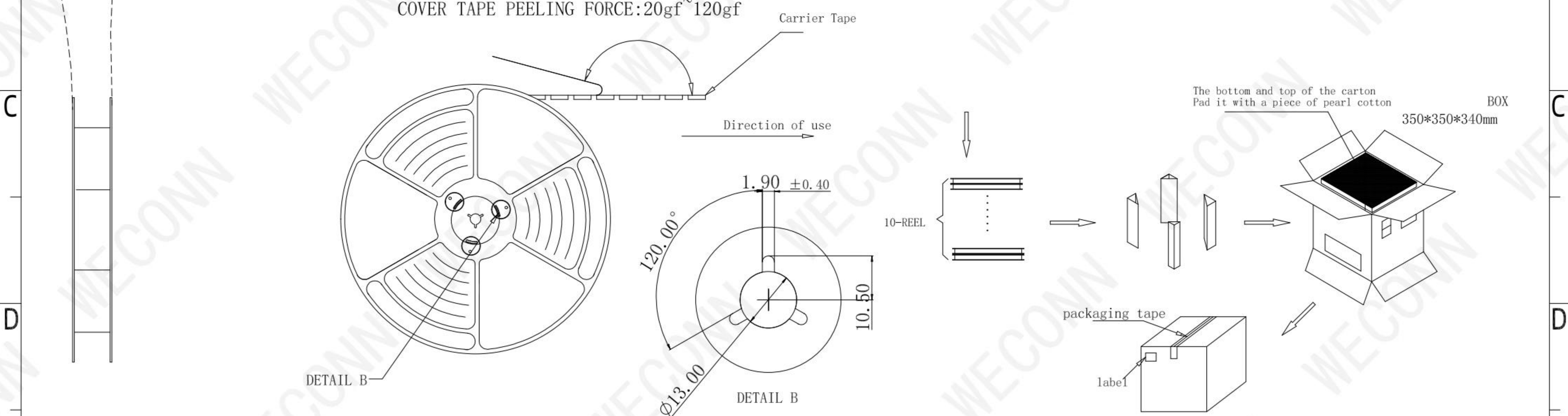

MILLIMETERS	INCH	UNITS	WECONN® 深圳市微连电子有限公司 ShenZhen Welink Electronics Co.,Ltd			
X. ± 0.2	X.° ± 5°	MM	PART NUMBER:		TITLE:	
.X ± 0.15	.X° ± 2°	MAT'L	WL-SIM113-027C		1.13H NO-PUSH NANO-SIM CARD	
.XX ± 0.1	.XX° ± 1°	SEE NOTES	DWG NO.:		APPD:	Cornelia
.XXX ± 0.01	.XXX° ± 0.5°	FINISH	WL-SIM113-027C		CHKD:	Mark
THESE DRAWINGS AND PECIFICATION ARE Welink ShenZhen Welink Electronics Co.,Ltd COPIED OR USED IN ANY MANNER WITHOUT Welink ShenZhen Welink Electronics Co.,Ltd			QTY	SCALE	SHEET	REV.
			SEE NOTES	1:1	2/2	A1
						DR: Michael